

Note: All connectors are numbered left to right facing the Power Panel NOT THE MEADE PUBLISHED PIN ORDER.

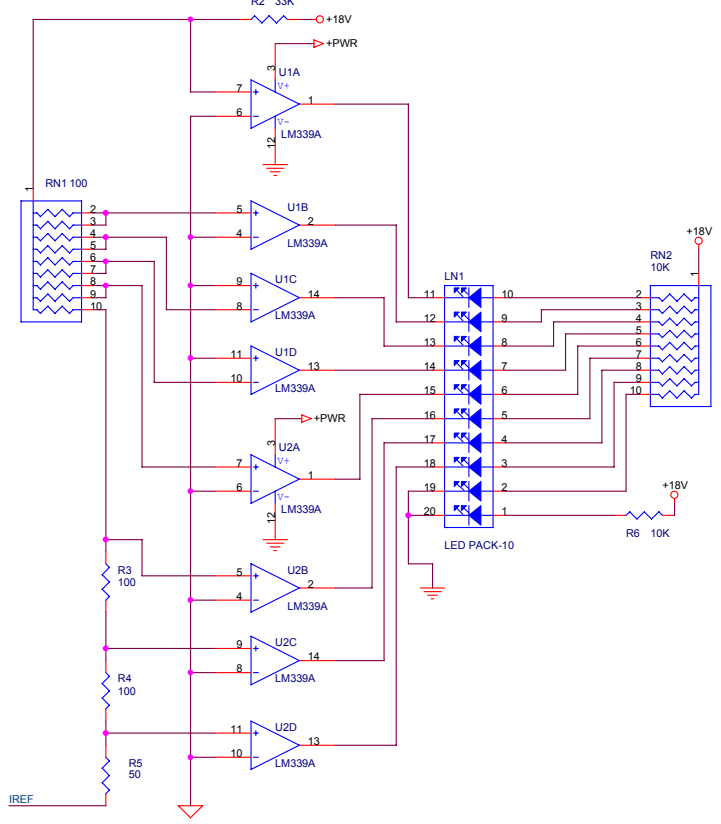

Note: All connectors are numbered left to right facing the Power Panel NOT THE MEADE PUBLISHED PIN ORDER.

TelescopeService.com		
Title MEADE LX200 Classic - Power Panel		
Size B	Document Number 834-2000	Rev A
Date: Thursday, January 02, 2003	Sheet 1 of 1	

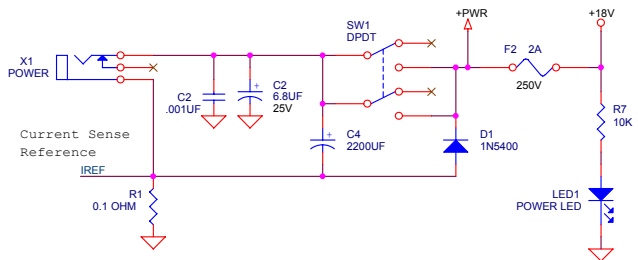
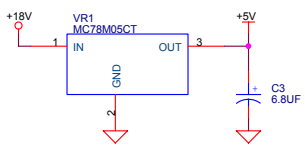
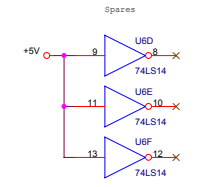
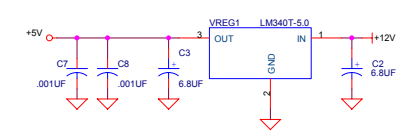
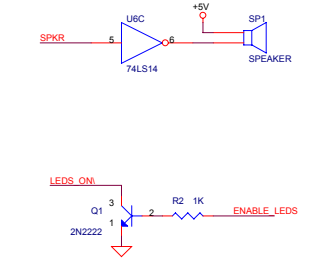
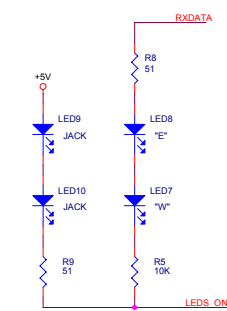
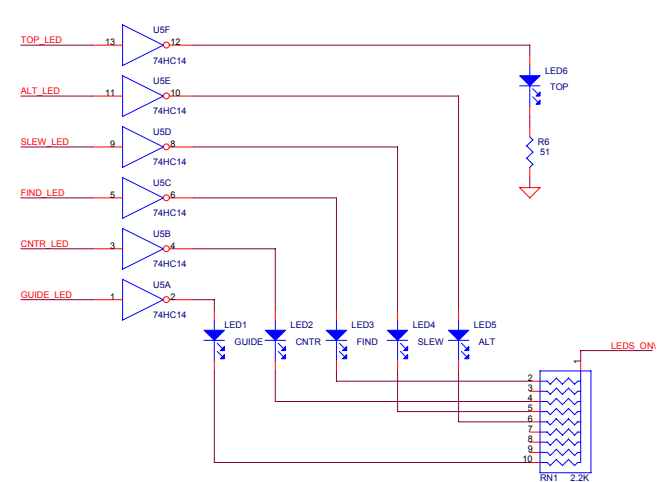
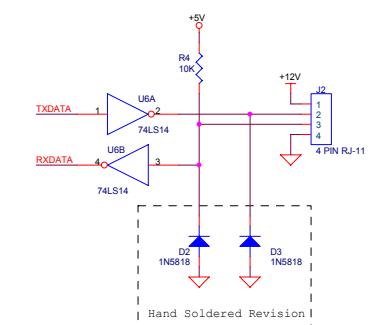
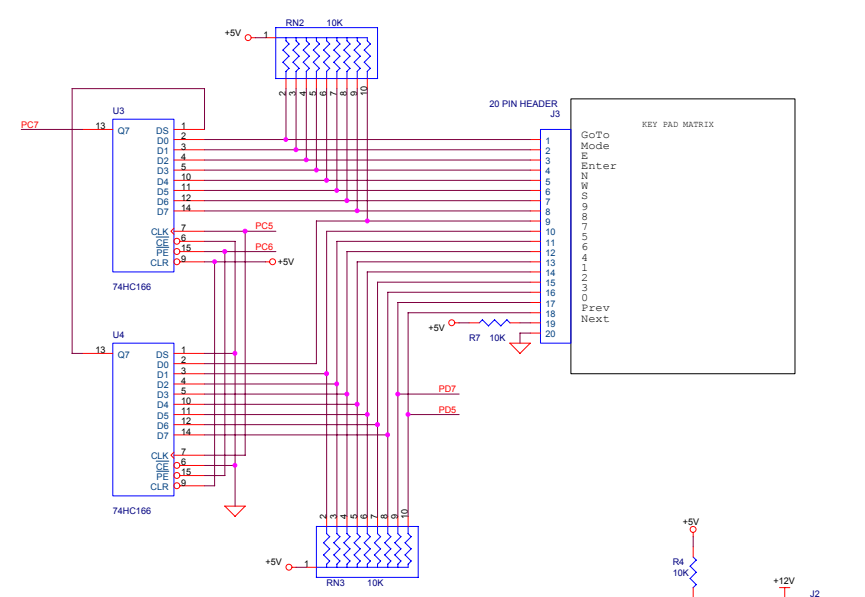
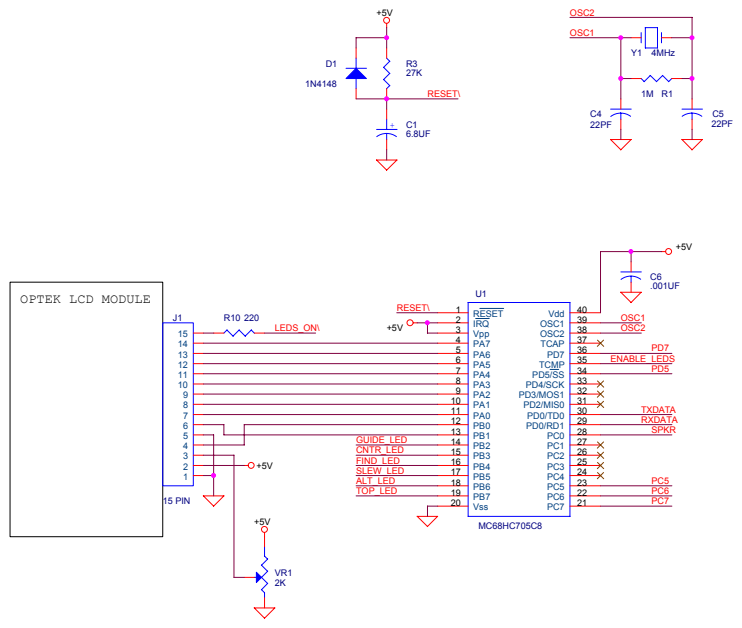

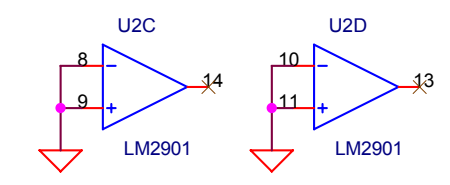
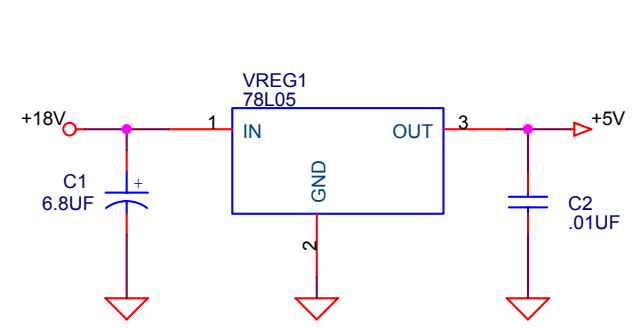
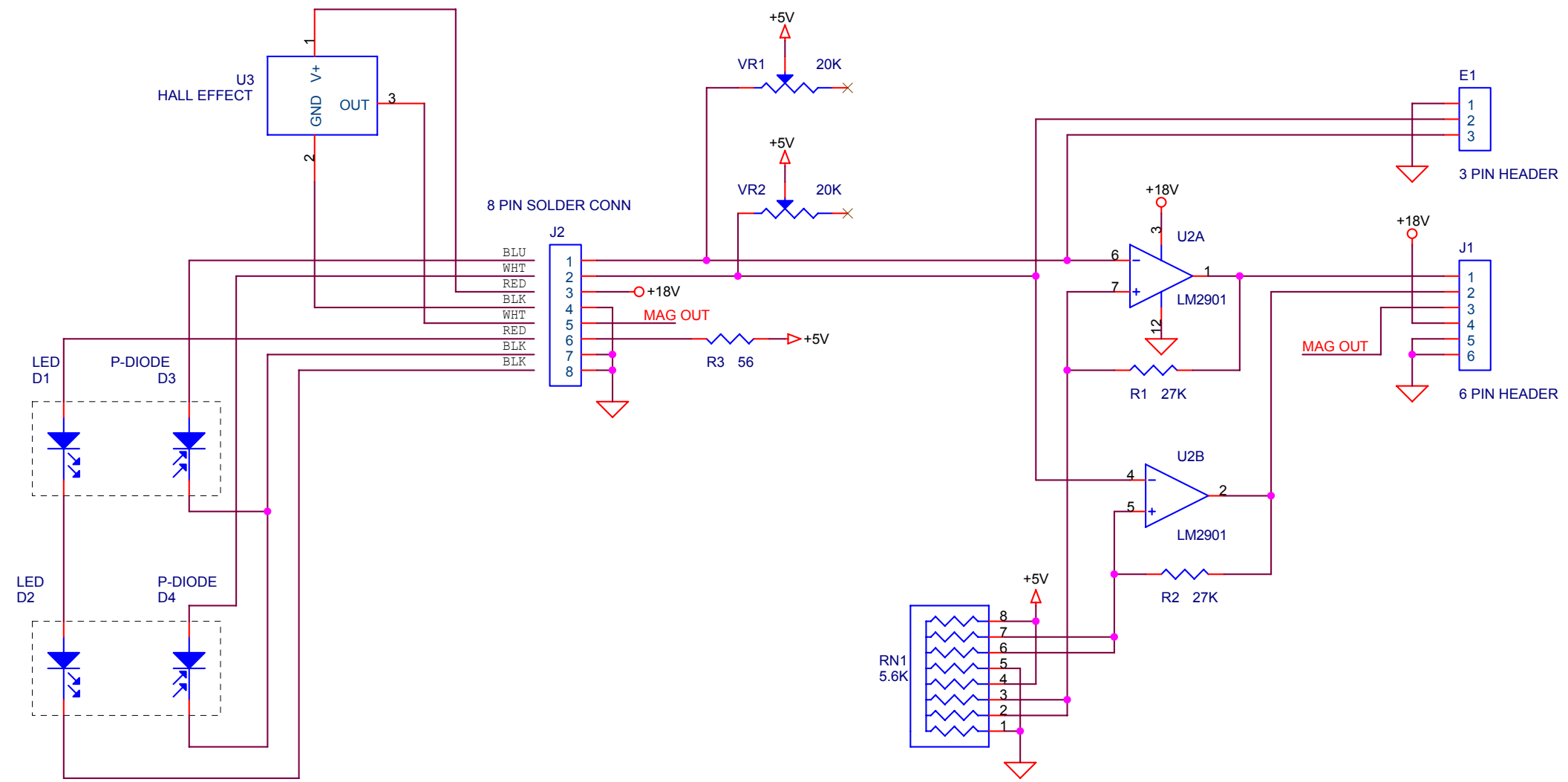

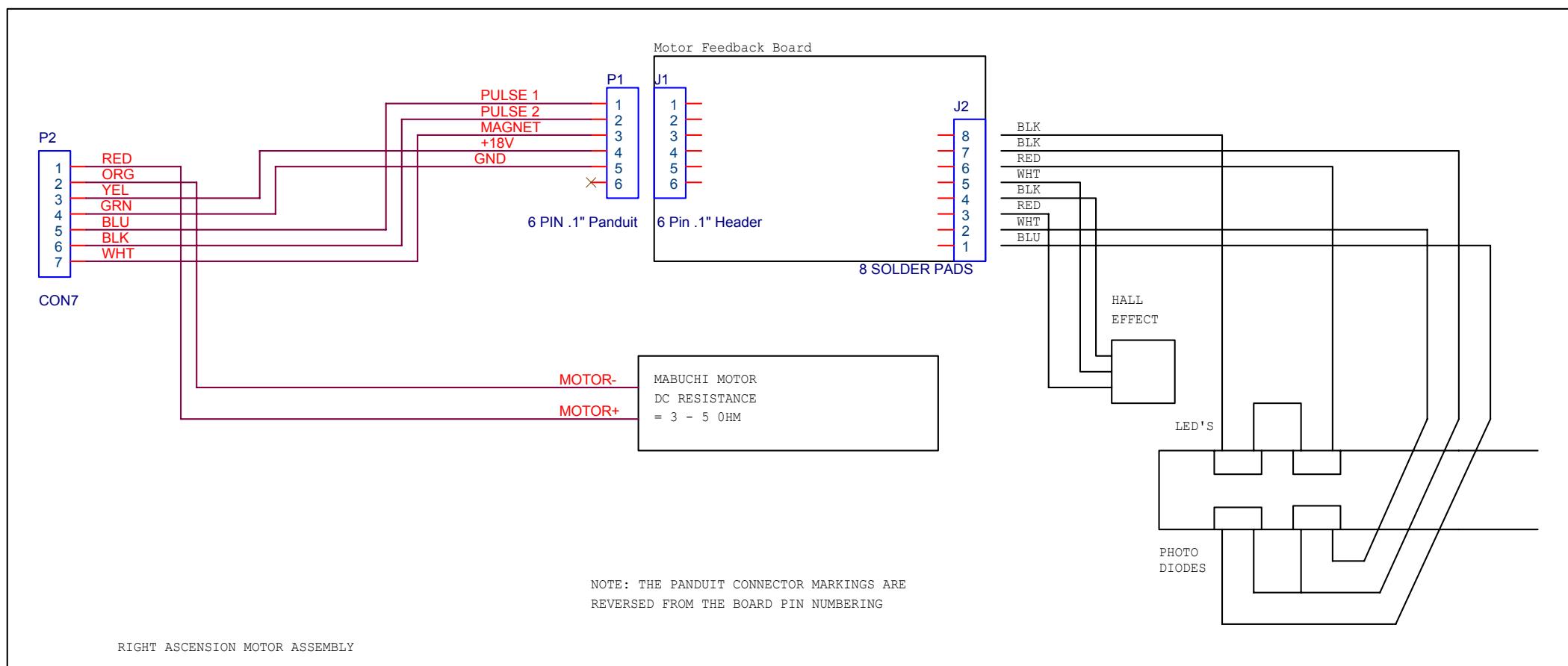
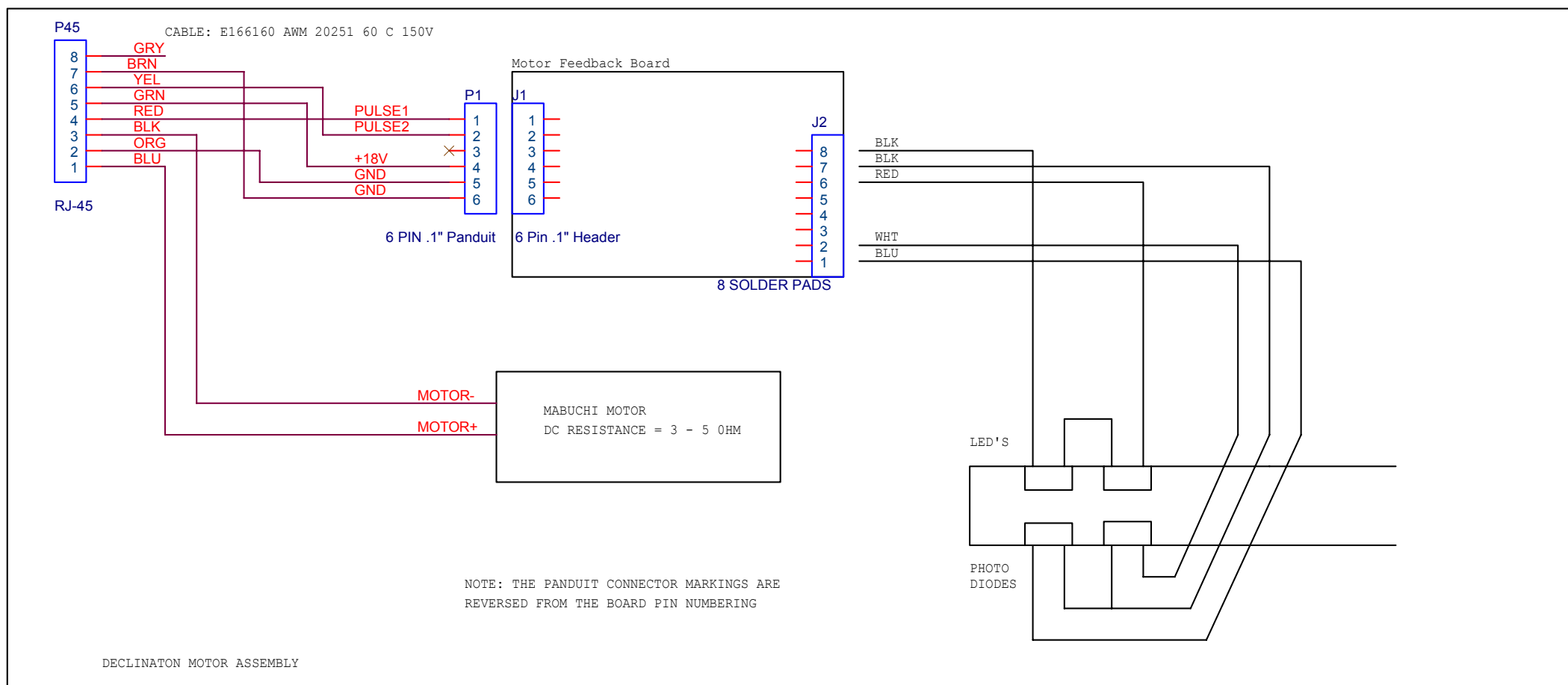

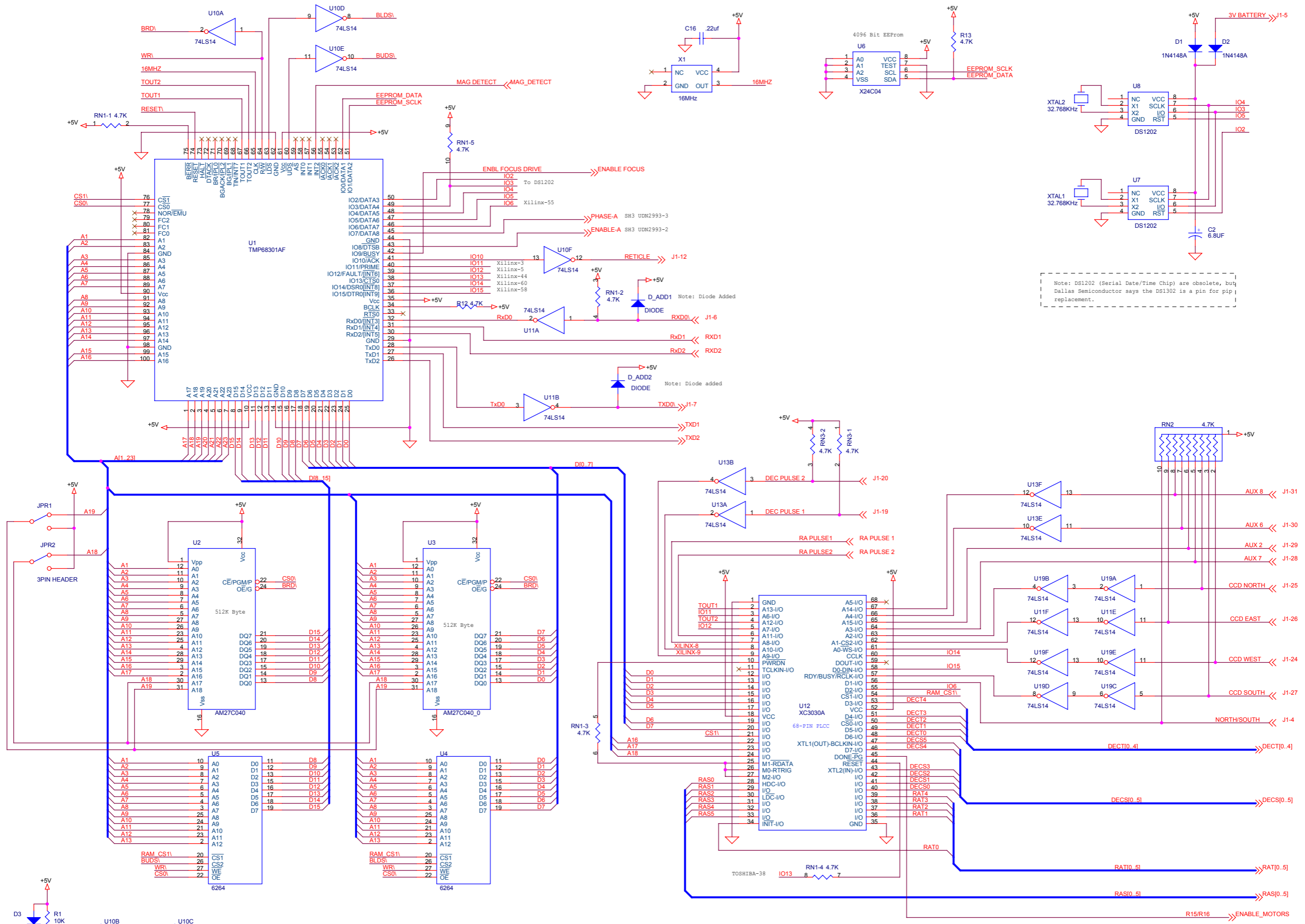

Note: DS1202 (Serial Date/Time Chip) are obsolete, but Dallas Semiconductor says the DS1302 is a pin for pin replacement.

